

## Power Quality Enhancement in Smart Grid System

MissR.Preetha<sup>1</sup>, Dharani.T<sup>2</sup>, Geethanjali.T<sup>3</sup>, Indhumathi.E<sup>4</sup>.

(Assistant professor, Electrical and Electronic Engineering, IFET College of Engineering,  
Anna university, India)

(student, Electrical and Electronic Engineering, IFET College of Engineering, Anna university, India)

(student, Electrical and Electronic Engineering, IFET College of Engineering, Anna university, India)

**Abstract:** In order to mitigate power quality disturbance in smart grid system due to voltage swells using one of the powerful power custom devices namely Dynamic Voltage Restorer (DVR). Almost all power quality problems originate from disturbances in the distribution networks. Power quality issues are gaining significant attention due to the increase in the number of sensitive loads. The DVR is normally installed between the source voltage and critical or sensitive load. Many of these loads use equipment that is sensitive to distortions or dips in supply voltages. Maximum AC loads consumes reactive power, it causes poor power quality in power system. The new configuration of DVR has been proposed using pic microcontroller. This method maintain a range in the smart grid and more useful for increasing the efficiency of load side equipment. We use ILBC based PV – DVR. By PV solar cell improving the stable power transfer limits of the interconnected grid system. The PV-DVR improves the stable distribution line substantially in the night and also in the day even while generating large amounts of real power.

**Keywords:** dynamic voltage restorer (DVR), interleaved boost converters, pic microcontroller

### I. Introduction

Electrical energy is the simple and well regulated form of energy, can be easily transformed to other forms. Along with its quality and continuity has to maintain for good economy. Power quality has become major concern for today's power industries and consumers. Power electronic devices i.e. interleaved boost converter (ILBC) and Dynamic Voltage Restorer (DVR) been recently used for voltage sag/swell compensation. Figure 1 explains DVR is proposed which can protect the end-consumer load from any unbalance of voltage supply and in this project interleaved boost converter are been used to improve the voltage level. DVR is used to reduce the voltage disturbances such as voltage sag, swell, harmonics. Voltage source inverter, series injection transformer, filtering and energy storage device connected to the dc-link

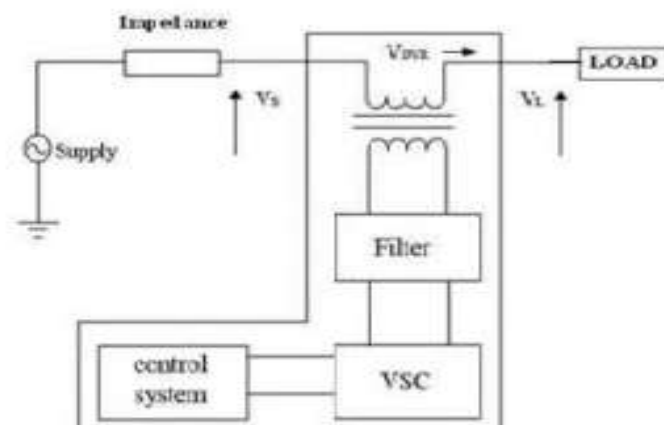

Fig 3.2 Schematic diagram of DVR

Figure1 Schematic diagram of DVR

This project addressed the new technique of DVR controller in order to compensate the voltage disturbances in distribution system.

**DESCRIPTOIN OF DVR**

This project is divided into three section. The explanation of each sections are as follows: section I describes a DVR and explain of itsfunction. ILBC operation discussed in section II. The simulation results are discussed in section III.

**SECTION I**

Figure 2 explains DVR is connected in series between the source voltage and sensitive loads through injection transformer. These types of energy storages are very important in order to supply active and reactive power to DVR the inverter ensures that only the swells or sag voltage is injected to transformer.

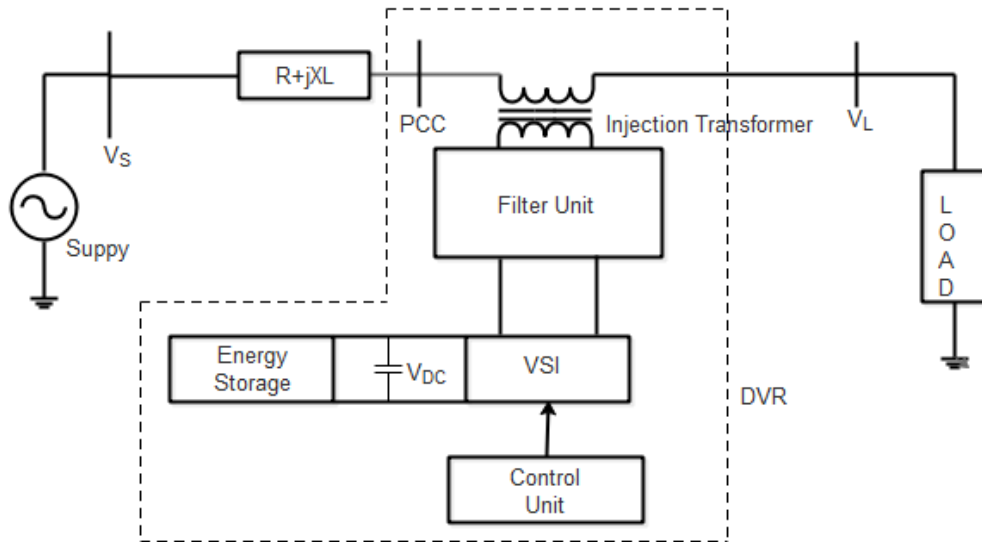

Figure 2: Typical DVR circuit (single-phase representation).

**SECTION II**

**Interleaved Boost Converter**

Figure 3 explainsThe interleaved boost converters consists of several identical boost converters connected in parallel and controlled by the interleaved method which has the same switching frequency and phase shift. Ripple cancellation both in the input-output voltage and current waveforms, reduced current peak value, and high ripple frequency are some of the benefits of interleaving operation in converters.

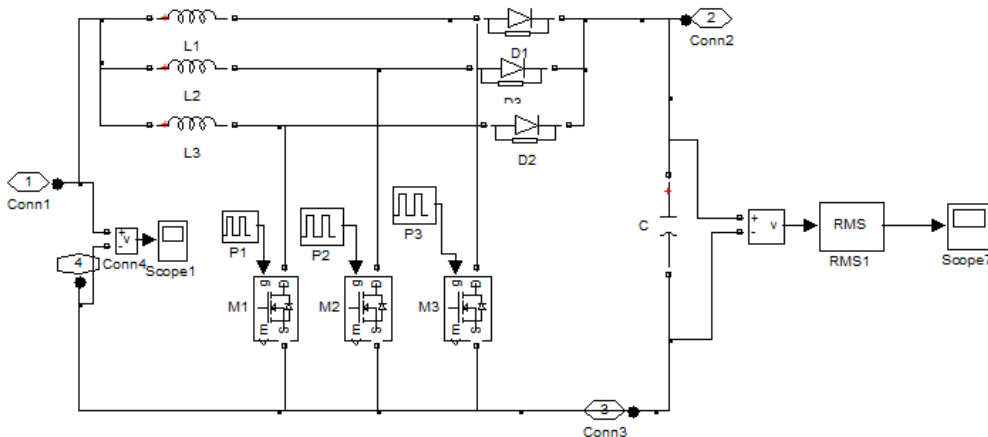

Figure 3 ILBC

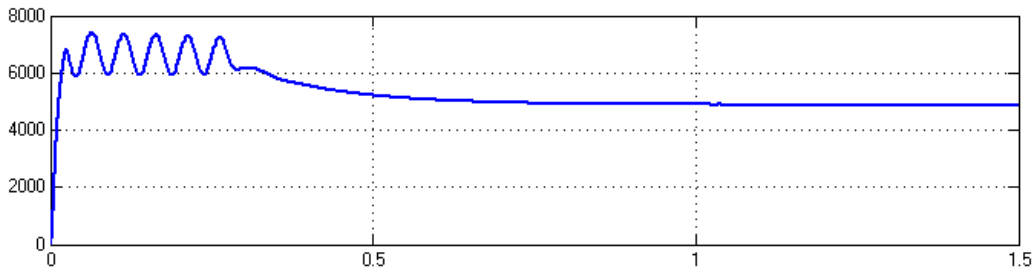

Figure 3.1 Output voltage of ILBC

### SIMULATION RESULTS III

The DVR is commonly used for voltage sags mitigation and harmonic elimination at the point of connection. Thevsc generates a three phase ac output current is controllable in phase and magnitude. these current are injected in the distribution system in order to maintain the voltage

Its purpose:

1. Elimination of current harmonics.
2. correction of power factor.
3. improve the voltage.

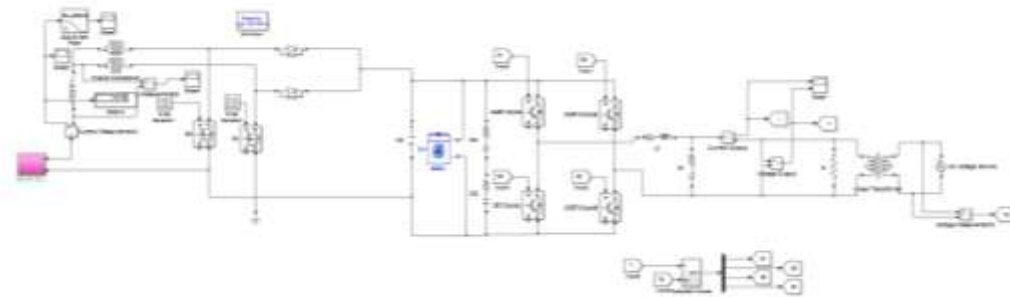

Figure 4 DVR connected in 11kv distribution system

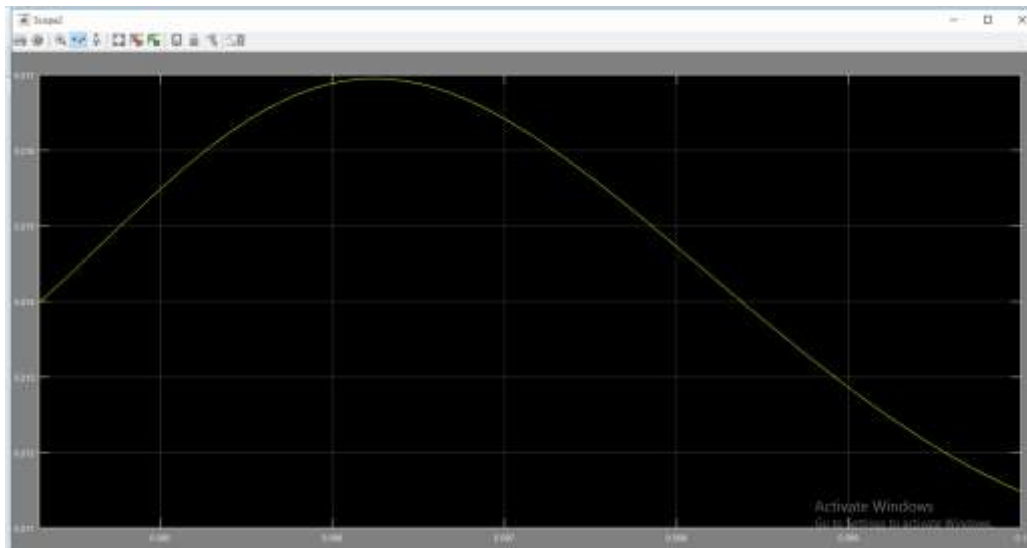

Figure 4.1 Actual Voltage with inductive load

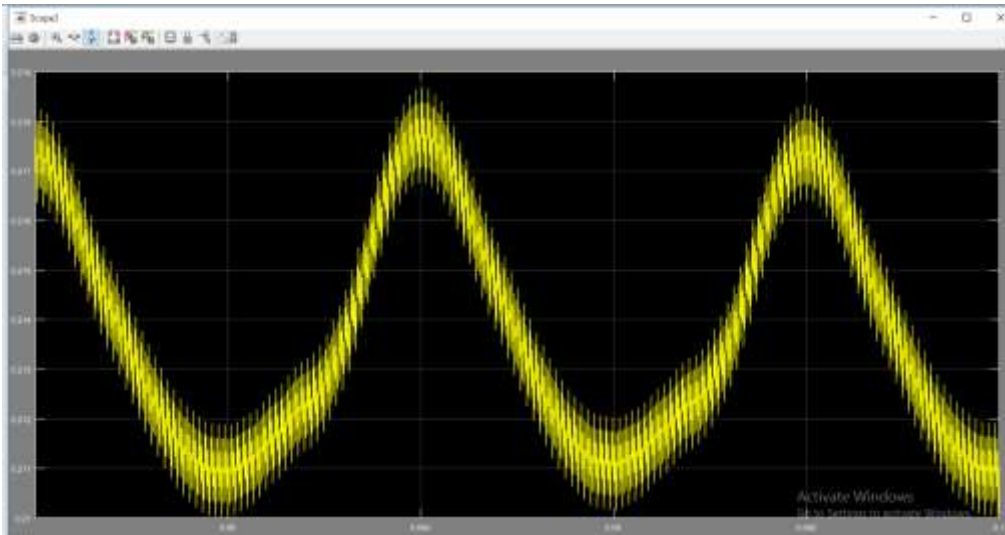

Figure 4.2 Load voltage with inductive load in the compensated line

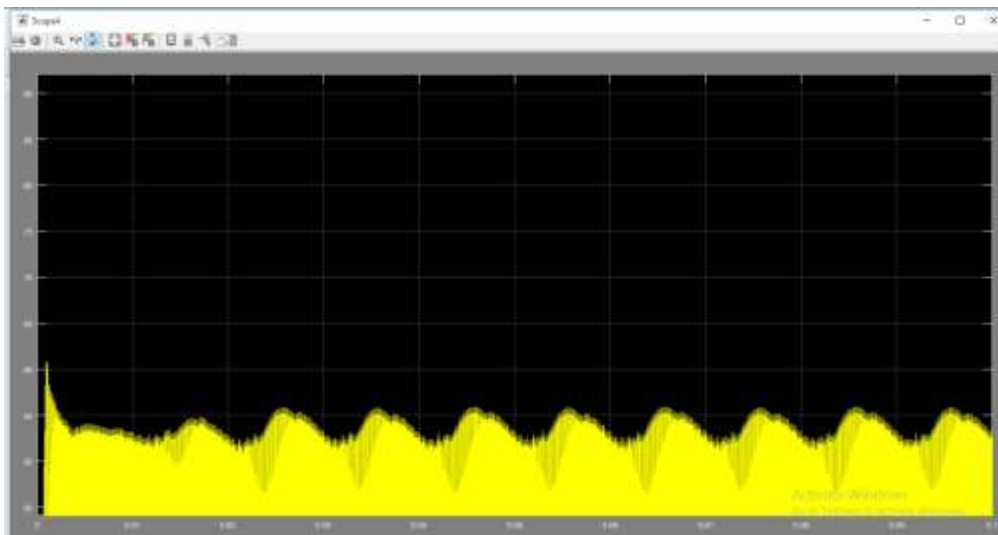

Figure 4.3 Load voltage with inductive load in the uncompensated line

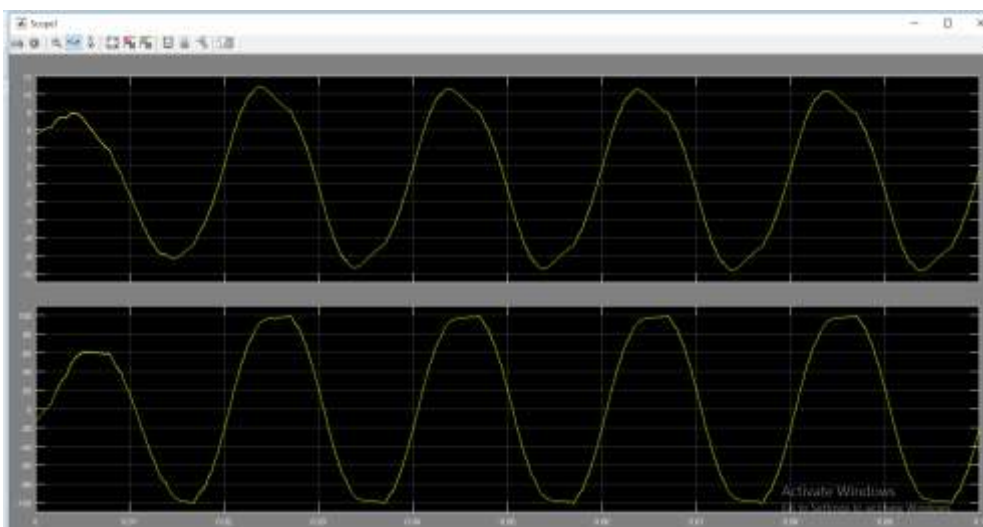

Figure 4.4 Voltage variation in the inductive load

## **II. Conclusion**

In this project, a control algorithm has been proposed for the generation of reference load voltage for a voltage-controlled DVR. The performance of the proposed scheme is compared with the traditional voltage-controlled DVR. The proposed method provides the following advantages: at nominal load, the compensator injects reactive and harmonic components of load currents, resulting in UPF; nearly UPF is maintained for a load change; fast voltage regulation has been achieved during voltage disturbances; and losses in the VSI and feeder are reduced considerably, and have higher sag supporting capability with the same VSI rating compared to the traditional scheme. The simulation and experimental results show that the proposed scheme provides DVR, a capability to improve several PQ problems

## **References**

- [1]. M. Bollen, *Understanding Power Quality Problems*. Piscataway, NJ, USA: IEEE, 2000, ch. 1, pp. 1–35. [2] H. Fujita and H. Akagi, "Voltage-regulation performance of a shunt active filter intended for installation on a power distribution system," *IEEE Trans. Power Electron.*, vol. 22, no. 3, pp. 1046–1053, May 2007.
- [2]. A. Ghosh and G. Ledwich, "Load compensating DVR in weak ac systems," *IEEE Trans. Power Del.*, vol. 18, no. 4, pp. 1302–1309, Oct. 2003. [4] A. Elnady and M. Salama, "Unified approach for mitigating voltage sag and voltage flicker using the DVR," *IEEE Trans. PowerDel.*, vol. 20, no. 2, pt. 1, pp. 992–1000, Apr. 2005.
- [3]. S. Rahmani, A. Hamadi, and K. Al-Haddad, "A Lyapunov-functionbased control for a three-phase shunt hybrid active filter," *IEEE Trans. Ind. Electron.*, vol. 59, no. 3, pp. 1418–1429, Mar. 2012.
- [4]. M. K. Mishra and K. Karthikeyan, "A fast-acting dc-link voltage controller for three-phase DVR to compensate ac and dc loads," *IEEE Trans. Power Del.*, vol. 24, no. 4, pp. 2291–2299, Oct. 2009.